

Autoclave Engineers

Bench Top Reaction Systems - Micro -BTRS[®]

Model BTRS - Jr[®]



*Micro-Scale Bench Top Reaction Systems
for Catalyst Research and Development*

**Autoclave
Engineers** 

Division of Snap-tite, Inc.

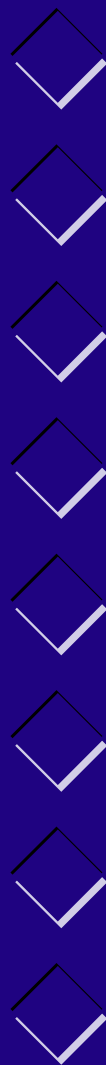

BTRS - Jr[®] System Description

The BTRS - Jr[®] is a complete reaction system for vapor phase catalyst evaluation and continuous flow process analysis. The reactant preparation portion is capable of handling up to four inputs. Two inputs can be high pressure liquid pumps. The reactants are passed through an optional **MIXER/VAPORIZER ASSEMBLY** for blending and creation of a single homogeneous, non-pulsating stream to be fed to the reactor.

The **MANUAL FEED CONTROLS** include high pressure metering valves, in-line filters, reverse-flow check valves, and a 3-way diverter valve. These valves permit on/off control and flow measurement of fluids prior to being directed into the system. These controls are mounted on the front panel of the reactor module.

One thermostated, **FIXED-BED TUBULAR REACTOR** is provided with a single-zone heater controlled from the catalyst bed (process) thermocouple.

The reactor and heater are mounted within an isothermal oven. A forced convection blower assembly provides heating for the oven. This totally heated environment ensures that undesirable condensation is minimized. This adds significantly to the performance and reproducibility achievable in a BTRS[®].

The optional multi-port **REACTOR STATUS VALVE** can permit reactant bypass. This valve provides a convenient means of performing analytical sampling of the feed material. When the reactor is placed in the "by-pass" position, a high pressure, inert gas stream is activated to purge the reactor contents to a safe vent.

Pressure measurement at the inlet of the reactor is performed via a **MECHANICAL GAUGE ASSEMBLY**. The gauge is isolated from the hostile reacting environment by a high pressure, silicone-filled isolator with a welded stainless steel diaphragm. Pressure is maintained by a manually-controlled, spring-loaded, **BACK PRESSURE REGULATOR**. Digital indication of pressure and closed-loop pressure control are also available as options.

A heated multi-port, near zero dead-volume, **SAMPLING VALVE** can be provided for transfer of the vapor phase effluent from the system to a customer-supplied gas chromatograph. This valve is also located in the isothermal oven. An optional heated transfer line and carrier gas controls are provided for sample transfer to a customer supplied gas chromatograph.

System control consists of three tunable PID controllers for temperature control of the reactor, oven, and transfer line. Also included are push-button switches to permit rotation of the multi-port reactor status and sampling valves.

A rupture disc assembly is included as a standard feature to eliminate the risk of dangerous over pressurization. A multi-port reactor status valve allows purging of the reactor during a shutdown. Power is terminated to any heater station with a burned-out or open sensor via the individual temperature controller.

BTRS - Jr[®] Applications

Chemical

- Hydrogenation
- Functional Group Modification
- Selective Oxidation
- Ammoxidation
- Isomerization

Environmental

- Liquid Waste Disposal
- Total Oxidation
- Effluent Treatment
- Resource Conservation

Petrochemical

- Cracking
- Reforming
- Isomerization
- Fisher-Tropsch

Food & Pharmaceutical

- Fermentation
- Supported-Enzyme Catalysis
- Hydrogenation

BTRS - Jr® Product Specifications

General

SYSTEM RATINGS: (Recommended Maximum)	System Pressure: 450 psi / 1450 psi / 2900 psi (31 Bar / 100 Bar / 200 Bar) Reactor Temperature: 650° C (1,202° F) Oven Temperature: 250° C (482° F)
DIMENSIONS:	Cabinet: 41" (105cm) Wide x 33" (82cm) Tall x 14" (35cm) Deep Oven: 12" (30cm) Wide x 24" (61cm) Tall x 8" (20cm) Deep
POWER SUPPLY:	220 VAC, 50/60 Hz, 20 Amp service, single phase
WETTED MATERIALS: §	300 Series Stainless Steel, Teflon® (PTFE), Kalrez®, Nitronic® 60, Vespel® (polyimide), [Nickel alloy A-286] (A-286 is on the 20 & 40 ml 2,900 psi (200 Bar) models only)
BULKHEAD CONNECTIONS:	Compression fittings for stainless steel tubing with nominal 1/8" OD and 1/16" ID
FILTER RATING:	7 Micron
CHECK VALVES:	O-ring seal design, 20 psi (1.4 Bar) cracking pressure
METERING VALVES:	18 turn, 0.047" (1.19 mm) orifice, 1° stem, .010 Cv, micrometer handle
BALL VALVES:	3-way, 180° actuation for directional flow switching and shut-off
THERMOCOUPLES:	Type "K" (Nickel-Chromium & Nickel - Aluminum)
TUBING	1/8" OD x 1/16" ID 316 Stainless steel seamless tubing

Teflon® and Vespel® are registered trademarks of Dupont Co., Wilmington DE • Kalrez® is a registered trademark of Dupont Dow Elastomer, Wilmington DE Nitronic® is a registered trademark of AK Steel Corporation, Middletown OH produced under license by Electralloy Div. of G.O. Carlson Inc., Oil City PA

Note: Autoclave Engineers Division of Snap-tite, Inc. reserves the right to substitute an equivalent material for trademarked material. Autoclave Engineers purchases substitute materials based on specification conformance, typically a widely accepted specification created by an industry standards organization.

Feed Preparation

Feed streams are provided for four (4) reactants, the purge gas, and the GC carrier gas. The purge gas feed controls are only supplied if the reactor status valve option is selected. The GC carrier gas feed controls are supplied only if the sample valve option is selected.

Reactant Feed Lines: Includes bulk-head connectors, inlet filters, metering valve, 3-way ball valve, and a check valve.

Purge / Feed Control: Includes bulk-head connectors, inlet filter, metering valve, 3-way ball valve, and a check valve.

GC Carrier Control: Includes bulk-head connectors, inlet filter, and a 3-way ball valve.

Oven Components

Mixer/Vaporizer: Optional unit includes four (4) inlet filters, and four (4) 54" (137 cm) coils for pre-heating gas and vaporizing liquids.

Pressure Gauge and Optional Transducer:

Gauge: 2-1/2" diameter face, dual scale, psi and Bar.

Pressure Transducer: Accuracy of +/-0.13% of full scale at constant temperature.

Isolator: 316 SS, silicone oil filled

Reactors: Select from 5, 10, 20, and 40-ml standard volumes. Includes inlet and outlet filters and full length internal thermowell.

Volume	Inner Diameter	Outer Diameter	Heated Length	Heater
5	0.31"/ 7.9mm	0.56"/14.3mm	6"/152.4mm	674 W
10	0.31"/ 7.9mm	0.56"/14.3mm	12"/304.8mm	1,348 W
20	0.52"/13.1mm	0.75"/19.1mm	6"/152.4mm	674 W
40	0.52"/13.1mm	0.75"/19.1mm	12"/304.8mm	1,348 W

Reactor Flow Direction: The standard tubing configuration creates downward flow, i.e. in the top and out the bottom, unless otherwise specified on the purchase order. Pre-bent tubing to produce the reverse reactor flow direction is included as loose parts with the unit.

"Trickle Feed" Connection: The standard end fitting of the tube reactor is equipped with an unused (plugged) connection. It can be used for feeding ingredients directly to the reactor through a dedicated line (which creates the possibility of independent temperature control) and bypasses the mixer vaporizer assembly.

Reactor Status Valve: Optional valve with 1/8" tube connections, 8 port, 2 position, air operated, push button activated, permits sampling of reactant feeds when used in combination with optional sampling valve. The reactor status valve is not available on 2,900 psi (200 Bar) models.

Sample Valve: Optional Valve with 1/8" tube connections, 8 port, 2 position, air operated, push-button activated. Captures a 1 ml sample (standard) of product and sends it to a customer supplied Gas Chromatograph. Autoclave Engineers can easily fabricate sample loops between 0.75 and 3.0 ml if capturing an alternate sample size is desired.

Back Pressure Regulator: Manually operated (standard) with optional automatic control. See table for control ranges.

§ The customer is responsible to confirm the compatibility of process fluids (at operating temperatures) with the wetted components of the reactor. The polyimide (used in the multi-port valves and the back-pressure regulator) has good resistance to most hydrocarbons and chemicals at 250° C (482° F). Polyimide has limited resistance to primary amines, ammonia and live steam. Contact the factory to discuss materials and process alternatives for solving compatibility problems.

BTRS - Jr® Product Specifications

Product Handling

Gas/Liquid Separator: The gas/liquid separator is located after the reactor and before the back pressure regulator. It includes a ball valve and metering valve for draining into a customer supplied collection tank.

Volume: 150 ml
Cooling Coil: 1/4" Copper Tube
Manual Drain: Metering Valve and 1/4 Turn Ball Valve

Heated Transfer Line: The heated transfer line connects the sample valve to a customer-supplied gas chromatograph (GC). It ensures a complete sample arrives at the GC by delivering it at elevated temperature to prevent any condensate formation.

Length: 6 feet (1.83m)
Inner Diameter: 0.027" (0.69mm)
Max Temp: 300°C
GC Adapter: Universal needle nut assembly including needles, septa, nut and ferrule to adapt to most GC's

Control System

Reactor Temperature: Closed Loop Digital Controller with 8-segment ramp-soak.
Reactor Wall Temperature: Over-Temperature Monitoring
Optional Pressure Indicator/Controller: Digital Pressure Indication or Pressure Indicating Controller
Optional GC Transfer Line: Closed Loop Digital Temperature Controller
System Failsafe Alarms: Over-temperature alarm to shut down all system heaters.
Data Acquisition: Consult Factory for additional control options.

Operating Pressure Ranges and Component Ratings

Maximum Recommended Operating Pressure	Gauge Range/ Transducer Range	Maximum Allowable Working Pressure	Back Pressure Regulator Range	Rupture Disk Rating
450 psi (31 Bar)	600 psi / 42 Bar 500 psi / 35 Bar	500 psi @ 1,202°F (35 Bar @ 650°C)	5-500 psi (0.3-35 Bar)	500 psi◇ (35 Bar)
1,450 psi (100 Bar) †	2,000 psi / 138 Bar 3,000 psi / 207 Bar	1,600 psi @ 1,202°F (110 Bar @ 650°C)	10-1,500 psi (0.7-103 Bar)	1,600 psi◇ (110 Bar)
2,900 psi (200 Bar) ‡	5,000 psi / 345 Bar 3,000 psi / 207 Bar	3,200 psi @ 1,202°F (220 Bar @ 650°C)	25-4,000 psi (1.7-276 Bar)	3,144 psi▣ (216 Bar)

† Autoclave Engineers assembles the 1,450 psi (100 Bar) model from stock components for rapid delivery

‡ Nickel alloy A-286 is substituted for 316 Stainless Steel for the 20 ml or 40 ml reactors used in 2,900 psi (200 Bar) models. This change increases strength at high temperature. Also, the optional "reactor status valve" is not available on 2,900 psi (200 Bar) models. All other specifications remain unchanged.

◇ The listed rupture disk rating is nominal. The specification range is +6% and -3%.

▣ The listed rupture disk rating is nominal. The specification range is +1.5% and -0.75%.

BTRS - Jr[®] General Arrangement

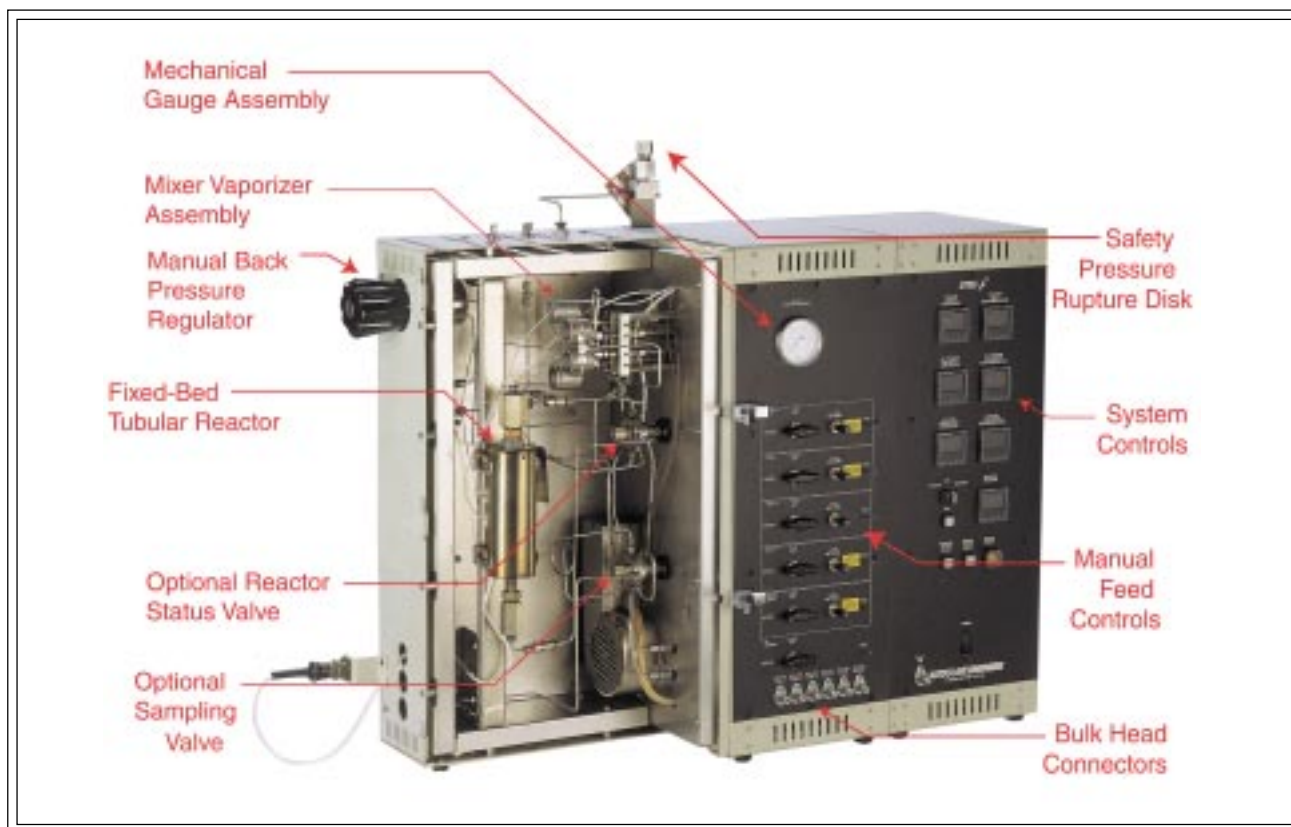

BTRS - Jr[®] Flow Schematic

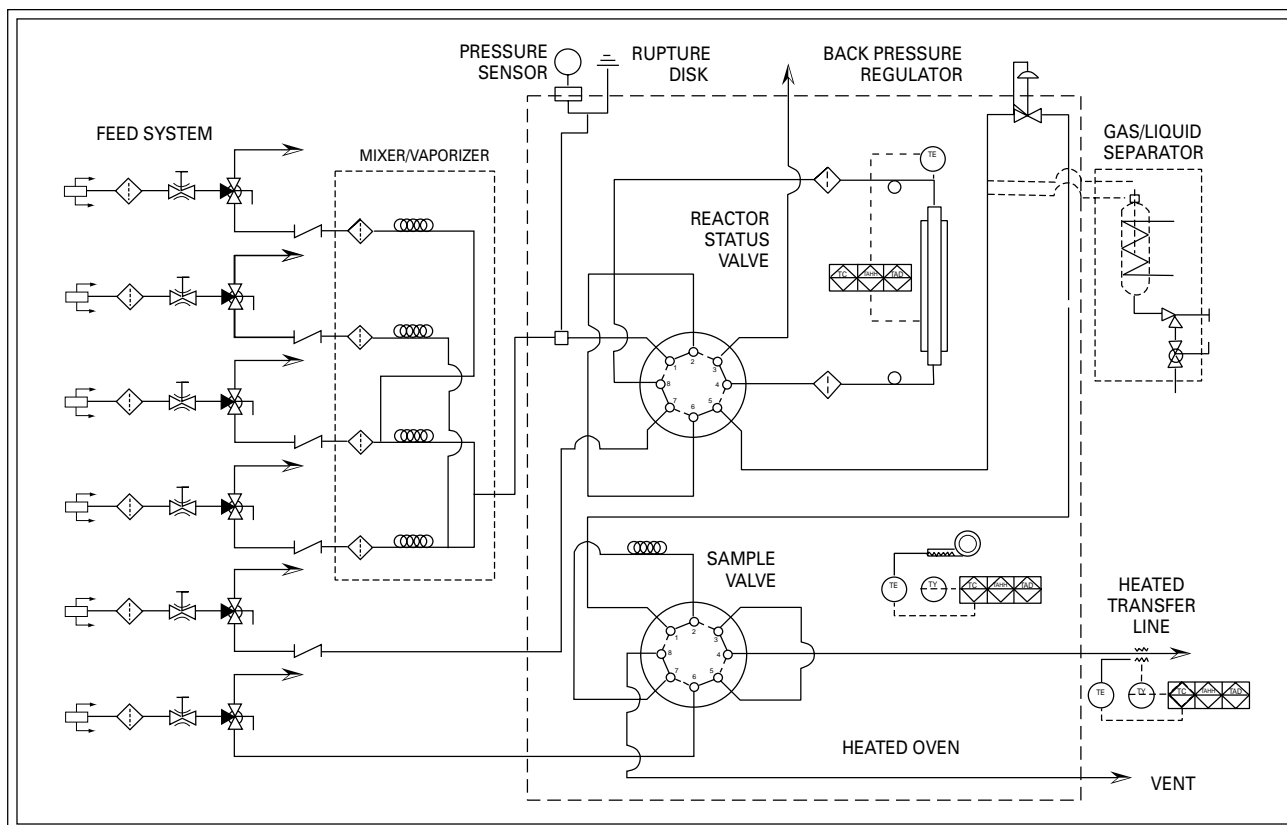

BTRS - Jr® Product Ordering Information

MODEL CODE: BTRS-JR A - B - C - D - E - F - G - H - J
BTRS-JR _ _ - _ _ - _ _ - _ _ - _ _ - _ _ - _ _ - _ _

A Base BTRS - Jr®

045 = 450 psi (31 Bar)
145 = 1,450 psi (100 Bar)
290 = 2,900 psi (200 Bar)+

B Reactor Volumes

005 = 5 ml
010 = 10 ml
020 = 20 ml
040 = 40 ml

C Mixer Vaporizer

0 = No
1 = Yes

D Reactor Status Valve +

0 = No
1 = Yes

E Pressure Monitoring and Control

0 = Analog Gauge / Manual Regulator
1 = Analog Gauge with Transducer and Digital Indicator / Manual Regulator
2 = Analog Gauge with Transducer / Automatic Regulator / Closed Loop Pressure Controller

F Sample Valve

0 = No
1 = Yes

G Heated Transfer Line

0 = No
1 = Yes

H Gas/Liquid Separator (Manual)

0 = No
1 = Yes

J Control Options

1 = Discrete Controls

+Reactor Status Valve NOT Available for 2,900 psi (200 Bar) unit.
For other pressure/temperature ranges, consult factory.

Supporting Information

Please refer to the following sections of the catalog for complimentary products and additional technical details. If your catalog is incomplete or out-of-date, feel free to register your name and download literature from Autoclave Engineers website. A good starting point is <http://www.snap-tite.com/divisions/ae/aed-index.html> to reach the main page of Autoclave Engineers reactor products.

- "High Pressure Micro-Metering Pumps" - Ideal liquid metering pumps for low viscosity feeds to the BTRS Family.
- "Customer Support Services" - Details Autoclave Engineers capabilities for start-up, training, and turnkey installation.

The following "Engineering Drawings" are available upon request from Autoclave Engineers for more detailed technical information.

Drawing Number 40A-9009 BTRS-Jr® Reactor Oven General Arrangement (illustrates 5 ml reactor and includes separator assembly)

Drawing Number 40A-9010 BTRS-Jr® Reactor Oven Process and Instrumentation Diagram

Drawing Number 20C-0241 Reactor Assembly (5cc, 316 SS)

Drawing Number 20C-2854 Reactor Assembly (10cc, 316 SS)

Drawing Number 20C-2855 Reactor Assembly (20cc, 316 SS)

Drawing Number 20C-2834 Reactor Assembly (40cc, 316 SS)

Drawing Number 20C-2760 Reactor Assembly (20cc, A-286/316 SS)

Drawing Number 20C-2856 Reactor Assembly (40cc, A-286/316 SS)



Division of Snap-tite, Inc.

2930 West 22nd Street
Erie, Pennsylvania 16506-2302 USA
PH: 814-838-5700 FAX: 814-838-5855
e-mail: aeclave_sales@snap-tite.com
www.autoclaveengineers.com



ISO-9001 Certified

06-0006PE-0301

! WARNING !

FAILURE OR IMPROPER SELECTION OR IMPROPER USE OF THE PRODUCTS AND/OR SYSTEMS DESCRIBED HEREIN OR RELATED ITEMS CAN CAUSE DEATH, PERSONAL INJURY AND/OR PROPERTY DAMAGE.

This document and other information from Snap-tite, Inc., its subsidiaries and authorized distributors, provides product and/or system options for further investigation by users having technical expertise. It is important that you analyze all aspects of your application and review the information concerning the product or system in the current product catalog. Due to the variety of operation conditions and applications for these products or systems, the user, through its own analysis and testing, is solely responsible for making the final selection of the products and systems and assuring that all performance, safety and warning requirements of the application are met. The products described herein, including without limitation, product features, specifications, designs, availability and pricing, are subject to change by Snap-tite, Inc. and its subsidiaries at any time without notice.

Bulletin RS-BTRS-Jr®