

# Autoclave Engineers Laboratory Stirred Reactors



**Autoclave  
Engineers** 

Division of Snap-tite, Inc.

- ◆ Autoclave Engineers has been associated with excellence in pressurized reaction equipment for over 50 years. Autoclave is noted not only for its history of safety and dependability, but also as an innovator in designs. The magnetically coupled agitator drive, MagneDrive®, was originally conceived and designed by Autoclave Engineers along with a series of innovative pressure vessel styles. We have taken advantage of this vast experience to establish an advanced line of stirred autoclaves for the research laboratory.
- ◆ The laboratory stirred reactor line adds a high degree of configuration flexibility to the established Autoclave Engineers' high quality designs. The modular configuration of the line allows one to customize the autoclave to specific needs using an extensive array of options, without paying a price or delivery penalty.
- ◆ Configuration starts with selection of vessel type based upon factors such as pressure and temperature requirements, volume, stand style and seal compatibility. Next, agitation is specified including torque requirements, impeller configuration, and motor type. Finally, select internal components, valving, and instrumentation to meet your research needs.

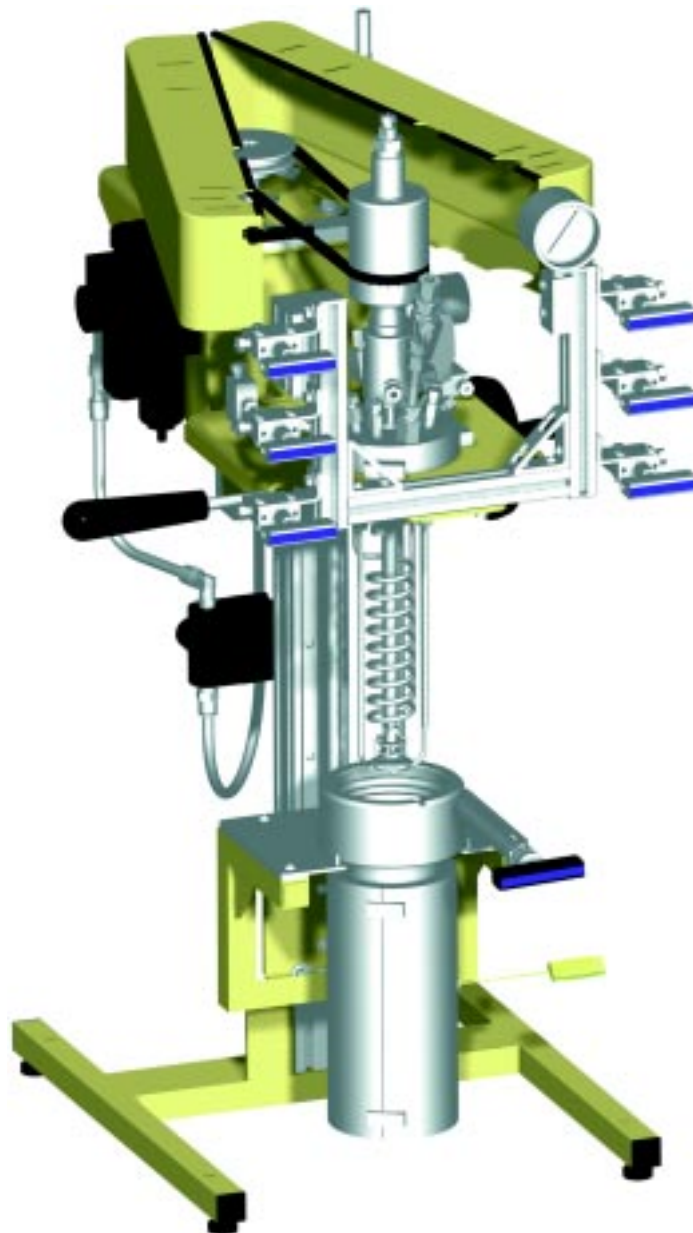

# Pressure Vessel

## Closure Style

Autoclave Engineers' offers three basic vessel closure styles. Select the style that meets your requirements for ease of opening and closing, seal compatibility, as well as pressure and temperature performance.

### ZipperClave®

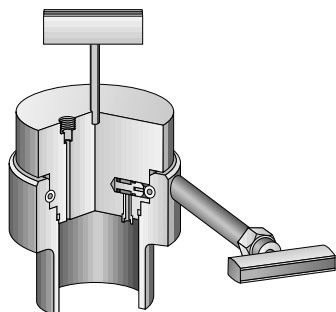

The ZipperClave® offers the quickest opening autoclave available. No bolts to torque, nor clamps or rings. Inserting a single spring section closes the vessel. The ZipperClave® uses an elastomeric O-ring for its pressure seal.

### EZE-Seal

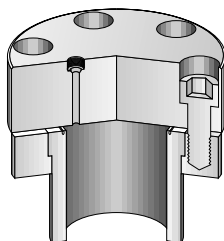

The EZE-Seal provides the ability to operate at high temperature and moderate pressure. The “loose flange” allows for easy interchange of vessel bodies. The seal design requires low bolting torque. The EZE-Seal may be equipped with either metal or elastomeric pressure seal.

### Bolted Closure

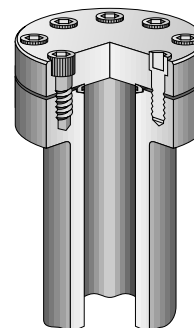

The Bolted Closure offers a high pressure capacity at moderate temperatures. The Autoclave Bolted Closure uses the Gasche metal gasket for its pressure seal.

**MAWP:** 2,200 psi @ 450° F  
(151 bar @ 232° C)

**Sizes:** 500 ml  
1,000 ml  
2,000 ml  
4,000 ml

**Seal Materials:**

Buna N  
Ethylene-Propylene  
PTFE  
Viton®  
Silicone  
Kalrez®

**Vessel Materials:**

ANSI 316 Stainless Steel  
HASTELLOY® C-276

**MAWP:** 3,300 psi @ 850° F  
(227 bar @ 454° C)

**Sizes:** 100 ml  
300 ml  
500 ml  
1,000 ml  
2,000 ml  
4,000 ml

**Seal Materials:**

Metal Double Delta  
Buna N  
Ethylene-Propylene  
PTFE  
Viton®  
Silicone  
Kalrez®

**Vessel Materials:**

ANSI 316 Stainless Steel  
HASTELLOY® C-276

**MAWP:** 5,500 psi @ 650° F  
(400 bar @ 343° C)

**Sizes:** 300 ml  
1,000 ml  
2,000 ml  
4,000 ml

**Seal Materials:**

Metal Gasket  
Buna N  
Ethylene-Propylene  
PTFE  
Viton®  
Silicone  
Kalrez®

**Vessel Materials:**

ANSI 316 Stainless Steel  
HASTELLOY® C-276

**Notes:** MAWP based upon Viton® seals, temperature and pressure ratings will vary depending upon seal material selected. See Bulletin “PV-ZIP” for details of vessel performance.

ASME Code Stamp not available for the Zipper Closure.

**Notes:** MAWP based upon metal seals, temperature and pressure ratings will vary depending upon seal material selected. See Bulletin “PV-EZE” for details of vessel performance.

**Notes:** MAWP based upon metal seals, temperature and pressure ratings will vary depending upon seal material selected. See Bulletin “PV-BC” for details of vessel performance.

## Working Dimensions/Conversion Kits:

Regardless of the closure style selection, the autoclave internal working dimensions are consistent for the various volumes. Conversion kits allow the interchange of vessel bodies and internals within reactors of common inside diameter and closure style. Interchangeable vessel sizes are: 100 & 300 ml; 500 & 1,000 ml; and 2,000 & 4,000 ml.

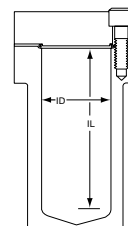

	100 ml	300 ml	500 ml	1,000 ml	2,000 ml	4,000 ml
<b>Inside Diameter</b>	1.81" (46 mm)	1.81" (46 mm)	3.0" (76 mm)	3.0" (76 mm)	5.0" (127 mm)	5.0" (127 mm)
<b>Inside Length</b>	2.75" (70 mm)	6.69" (170 mm)	4.59" (116 mm)	8.71" (221 mm)	6.06" (153 mm)	12.31" (312 mm)

## Flush Valve

Autoclave Engineers' laboratory reactors may be equipped with our bottom flush valve. The Autoclave Engineers' flush valve permits easy removal of vessel contents through its 1/2" NPT exit port. The closed valve provides a smooth vessel interior, free of dead zones.

*Note: A flush valve is only available on reactors 500 ml and larger. Due to space constraints, autoclaves with flush valves must be mounted in a floor type stand.*



## Codes and Approvals:

All Autoclave Engineers' pressure components are designed to ASME design criterion. Where required, ASME stamping may be applied. For our European uses, the Laboratory Stirred Autoclave line may be provided with a CE Declaration of Incorporation for Machinery, Low Voltage, and EMC Directives.

*Note: Not all options are capable of carrying the CE Mark. Also, ZipperClave® closures are not capable of carrying an ASME stamp.*

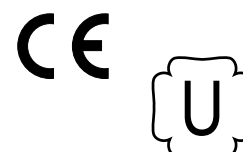

## Stands:

The laboratory series of reactors may be mounted in open stands which allow easy access to connections and components. There are four stands available for the laboratory stirred reactors; two benchtop models as well as light and heavy-duty floor stands.



**Bench Top Stand**



**Light-duty Floor Stand**



**Heavy-duty Floor Stand**

Stand Configuration				Overall Dimensions		
Style	100 & 300 ml	500 & 1000 ml	2000 & 4000 ml	Wide	Deep	Tall
Short Bench Top	✓			20.5" (521 mm)	26.2" (665 mm)	34.8" (884 mm)
Tall Bench Top		✓		20.5" (521 mm)	26.2" (665 mm)	39.4" (1001 mm)
Light-duty Floor		✓		25.0" (635 mm)	26.5" (673 mm)	61.8" (1570 mm)
Heavy-duty Floor			✓	28.4" (721 mm)	30.8" (782 mm)	61.6" (1565 mm)

## Lift Mechanism

All laboratory reactor stands are designed such that the top cover of the reactor is held in the stand and the vessel body drops away when opened. The body lift mechanism provides a mechanical assist for raising and lowering the body. The lift mechanism is recommended for all applications where frequent opening and closing of the reactor is required.



## Agitation

### MagneDrive®

All Autoclave Engineers' laboratory reactors feature the MagneDrive® magnetically actuated packless impeller system. Rare earth magnets provide high torque mixing effectiveness. Because the MagneDrive® is a sealed system there is no packing to wear causing leakage, contamination and costly downtime. Mixing speeds up to 3,300 RPM are possible to meet your specific requirements. The laboratory stirred reactor series is equipped with the MAG075 series MagneDrive®. The MAG075 series is an enhanced design which provides improved bearing life and ability to increase to unit's torque capacity with the substitution of a high torque stator module. This takes the static mixing torque from 7 in-lb (0.79 n-m) to 16 in-lbs (1.8 n-m)

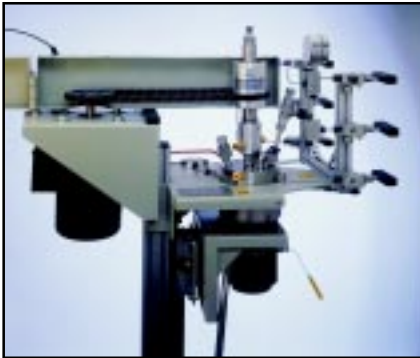

### Bearing Material:

Standard bearing material is Purebon® 658RCH<sup>1</sup>. Optional high-temperature polymeric bearings are available.

*Note: High-temperature polymeric bearings are not acceptable for all conditions, consult the factory for an evaluation of your application.*

### Speed Sensor:

The rotational speed of the MagneDrive® is monitored by a solid state magnetically sensitive pickup. The pickup is rated either general purpose or explosion-proof. The explosion-proof version requires intrinsic safety barriers.

*Note: Intrinsic Safety barriers are available as instrumentation accessories.*

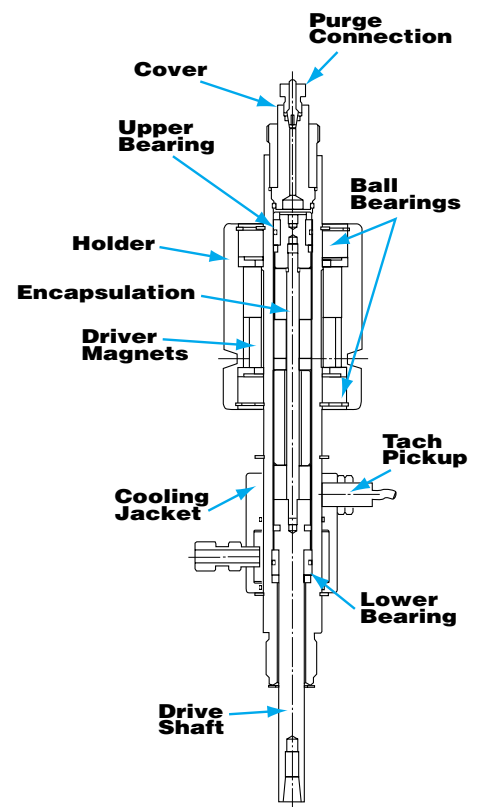

### Motor:

A variable speed motor that is connected using a drive belt powers the MagneDrive®. The belt drive includes a hinged guard for operator safety. There are several options for these agitation motors. The 1/2 HP DC electric motor options include general purpose or explosion-proof (Class I, Group C & D, Division 1) and 90 or 180 volt armatures. DC motors require electronic drives for adjustment of motor speed. The 1/2 HP AC electric motor has the CE mark for explosion proof service. It is a 230-400 VAC, 50Hz, inverter duty motor.

There are two air motor options. The manual speed adjust package includes: a 3/4 HP air motor, air regulator, air filter, and lubricator. The electronic speed adjust package includes: a 3/4 HP air motor, air filter, lubricator, air relay and I/P converter. This package allows the motor speed to be adjusted via a 4-20 mA signal from control instrumentation.

*Note: The 1/2 HP AC electric motor is the only option that has a CE Mark for explosion-proof service*

### Impeller:

There are several basic impeller styles offered in the laboratory stirred reactor line. The Dispersimax turbine-type impeller is well suited for gas/liquid reactions. It provides radial flow, while it draws gas down a hollow shaft and disperses it through the impeller for effective high speed stirring. The straight blade turbine (a.k.a. Rushton Turbine) is suited for gas/liquid applications requiring fairly high shear at high speeds. The axial flow or pitched blade turbine impeller is especially suited for high speed liquid/solid applications where tank baffles are impractical. The pitch angle is 45° and may be specified as either upward or downward flow.

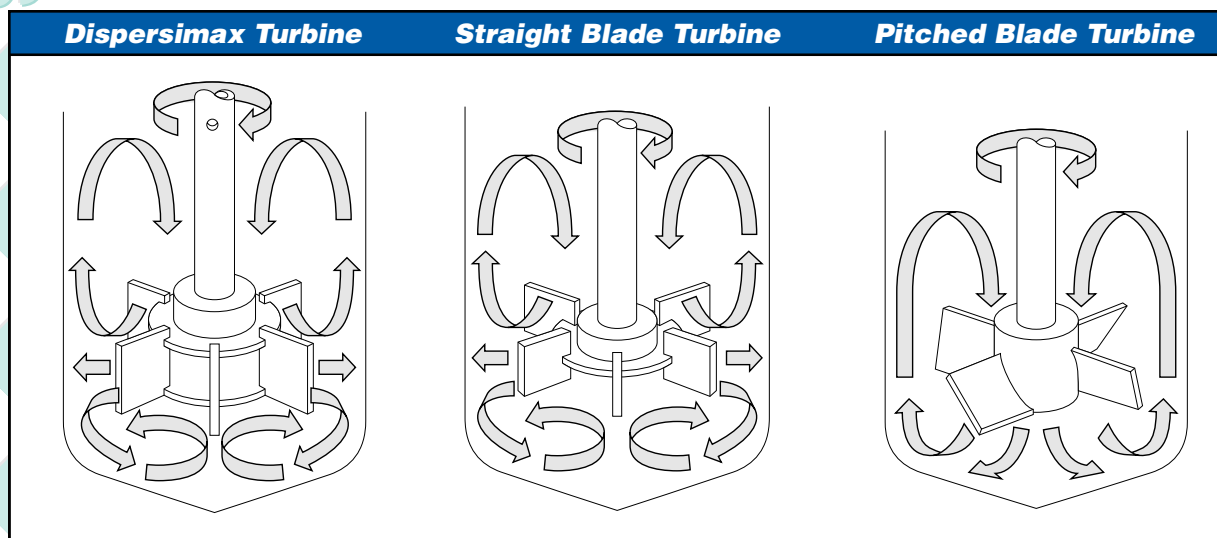

The straight blade and axial flow impellers are provided with solid agitator shafts. Removable baffle bars are included for all impeller styles.

Impeller diameters		
100-300 ml: .88" (22.4 mm)	500-1000 ml: 1.25" (31.8 mm)	2000-4000 ml: 2.0" (50.8 mm)

# Internal Accessories

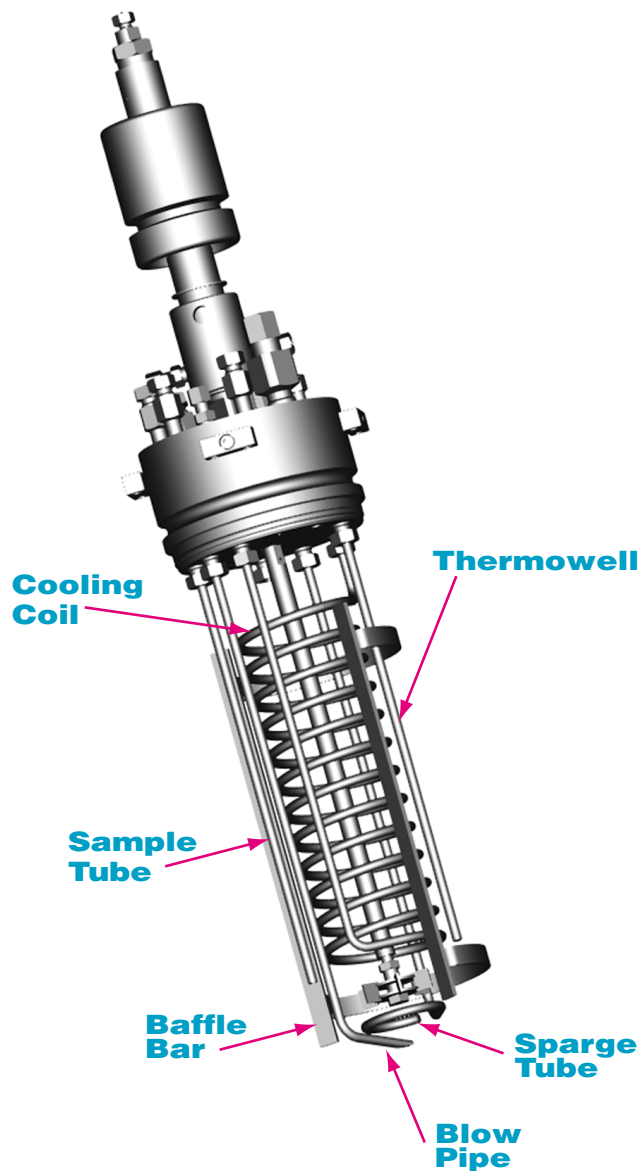

There are several internal accessories to pick from when configuring your stirred autoclave. Further, each accessory has the possibility of different variations. Many include manual valves which are conveniently located at the front of the unit.

## **Liquid Sample:**

The liquid sample tube allows the user to remove liquid from the lower portion of the autoclave. The sample is withdrawn through a top cover connection. The liquid sample accessory may be plugged at the top cover, or include a manual valve.

## **Blow Pipe:**

The blow pipe allows the user to empty the liquid contents of the autoclave via a tube formed to meet the lowest portion of the vessel. Gas pressure is used to force the contents through the tube and out via a top cover connection. This may also be used to move solids from the vessel bottom. The blow pipe accessory may be plugged at the top cover, or include a manual valve.

## **Sparge Tube:**

The sparge tube provides a means of injecting gas into the reactor below the liquid level. The gas is injected through a top cover connection. The sparge tube accessory may be plugged at the top cover, or include a manual valve.

## **Cooling Coil:**

The cooling coil provides a means of cooling the reactor contents by circulating media through an internal coil. The coolant inlet and outlet connections are located on the top cover. The cooling coil accessory may be provided: plugged at the top cover, with a manual inlet valve, (available in 120VAC, or 240VAC).

## **Process Thermocouple/ Thermowell:**

The thermowell provides a means of measuring process temperature using a thermocouple, which is inserted through the top cover. You can configure your reactor with thermowell only, or thermowell inclusive of either a Type "K" or Type "J" thermocouple.



# External Accessories

## **Vent Valve:**

The vent valve is a manual device which permits the user to exhaust headspace gases.



## **Pressure Gage / Transducer:**

Laboratory autoclaves may be equipped with a 2-1/2" (63.5 mm), dual scale (psig / bar) dial pressure gage or a combination of pressure gage and electronic pressure transducer. These pressure measurement accessories are available in the following ranges; 0-600 psig (0-41 bar), 0-1,000 psig (0-69 bar), 0-2,000 psig (0-138 bar), 0-3,000 psig (0-207 bar), 0-5,000 psig (0-345 bar), and 0-7,500 psig (0-517 bar). If a pressure measurement accessory is selected that has a lower pressure rating than the autoclave to which it is being attached, the overpressure device (rupture disk) will automatically be selected for protection of the pressure measurement device. The pressure transducer is a 2 wire type, with a 4-20 mA signal output.



## **Heating / Cooling**

There are numerous external heating (and cooling) options from which to choose. Single zone electrical furnaces may be 120 or 240VAC. Removable heating/cooling jackets are available for applications where a heat transfer system is used to control reactor temperature.



## **Gas Inlet:**

Each autoclave is provided with a gas inlet port in the top cover. The autoclave can be supplied with one or two (manifolded) valves which are connected to the gas inlet port. If no valves are selected the gas inlet port will be plugged.

### **Charging:**

One charging port is provided in each reactor top cover. This port is intended for charging of catalyst or like materials. The charging valve may be included. The charging valve is a "ball" type with a 1/4" diameter orifice. It is connected to 3/8" OD -1/4" ID stainless steel tube and is manually operated.



### **Furnace Thermocouple:**

It is recommended that any electric furnace employ an overtemperature device which monitors the skin (outside diameter) temperature of the autoclave. This is a safety device which prevents overheating due to shorted power controls. Both Type "K" and Type "J" thermocouples are available.

## *Other Accessories*

Autoclave Engineers offers additional ancillary components which may be needed to put your stirred autoclave to work. The Control Tower series controllers provide precise control and measurement of temperature, agitator speed, and pressure. Gas and liquid feed controls, product handling, data acquisition, and process automation are among the additional features we can offer. Our capabilities include complete, integrated systems, custom designed to your requirements.



Autoclave Engineers has been a pioneer, along with its partners in industry and academia, in the development of catalytic internals for its reactors. These specialized internals are also available for your new stirred autoclave.

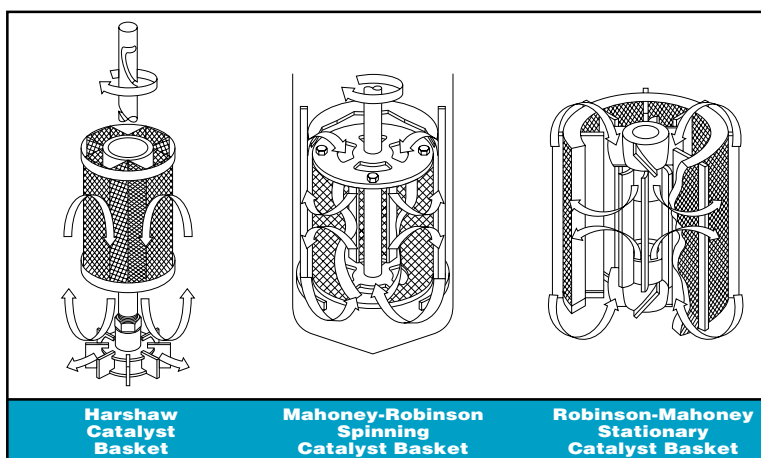

## Modifications and Custom Designs

Autoclave Engineers' standard stirred reactor products satisfy most researchers needs. However, your process may require specialized equipment. Autoclave Engineers has a long history of success in custom design that fulfills the customers need. We will work with the customer to quote specific equipment requirements. Contact your local sales representative for assistance in completing Autoclave Engineers' "Pressure Vessel and Stirred Reactor Applications Data Sheet." Feel free to complete the interactive version on the web at:  
<http://www.snap-tite.com/divisions/ae/pages/LabStirReac.html>

## Supporting Information

### Stirred Reactor Packages:

#### ZipperClaves®

500 and 1,000 ml  
2,000 and 4,000 ml  
Ordering Guide

Bulletin SR-ZC-500/1L  
Bulletin SR-ZC-2/4L  
Bulletin SR-ZC-OG

#### EZE-Seals

100 and 300 ml  
500 and 1,000 ml  
2,000 and 4,000 ml  
Ordering Guide

Bulletin SR-EZ-100/300  
Bulletin SR-EZ-500/1L  
Bulletin SR-EZ-2/4L  
Bulletin SR-EZ-OG

#### Bolted Closure

300 ml  
1,000 ml  
2,000 and 4,000 ml  
Ordering Guide

Bulletin SR-BC-300  
Bulletin SR-BC-1L  
Bulletin SR-BC-2/4L  
Bulletin SR-BC-OG

### Pressure Vessels:

Zipper Closure  
EZE-Seal  
Bolted Closure

Bulletin PV-ZIP  
Bulletin PV-EZE  
Bulletin PV-BC

### MagneDrive®:

MAG075

Bulletin AGT-MAG075

### Control Instrumentation:

Tower Controller

Bulletin INST-TOWER

Product information can be downloaded after registering your name on the Autoclave Engineers website. A good starting point is <http://www.snap-tite.com/divisions/ae/aed-index.html> to reach the main page of Autoclave Engineers reactor products.

Viton® and Kalrez® are registered trademarks of DuPont Dow Elastomers, Wilmington, DE.

Purebon® is a registered trademark of Morgan Advanced Materials and Technology Inc. - Pure Carbon Div., St. Marys, PA.

HASTELLOY® is a registered trademark of Haynes International Inc., Kokomo, IN.

NOTE: Autoclave Engineers Division of Snap-tite, Inc. reserves the right to substitute an equivalent material for trademarked material. Autoclave Engineers purchases substitute materials based on specification conformance, typically a widely accepted specification created by an industry standards organization.



Division of Snap-tite, Inc.

2930 West 22nd Street  
Erie, Pennsylvania 16506-2302 USA  
PH: 814-838-5700 FAX: 814-838-5855  
e-mail: [aeclave\\_sales@snap-tite.com](mailto:aeclave_sales@snap-tite.com)  
[www.autoclaveengineers.com](http://www.autoclaveengineers.com)

ISO-9001 Certified



### ! WARNING !

FAILURE OR IMPROPER SELECTION OR IMPROPER USE OF THE PRODUCTS AND/OR SYSTEMS DESCRIBED HEREIN OR RELATED ITEMS CAN CAUSE DEATH, PERSONAL INJURY AND/OR PROPERTY DAMAGE.

*This document and other information from Snap-tite, Inc., its subsidiaries and authorized distributors, provides product and/or system options for further investigation by users having technical expertise. It is important that you analyze all aspects of your application and review the information concerning the product or system in the current product catalog. Due to the variety of operation conditions and applications for these products or systems, the user, through its own analysis and testing, is solely responsible for making the final selection of the products and systems and assuring that all performance, safety and warning requirements of the application are met.*

*The products described herein, including without limitation, product features, specifications, designs, availability and pricing, are subject to change by Snap-tite, Inc. and its subsidiaries at any time without notice.*